

**CIRCO**  
CIR700-S

# SPECIFICATIONS

**LUMIXE**  
MIRRORING A BRIGHTER HOME



## SKU CIR700-S

### Size

- W 700mm
- H 700mm
- D 35mm
- N.W. 5.65KG

### Features

- Touch buttons
- 3 LED Colour temperatures
- Light dimmable
- Mirror Demister with auto cut-off time
- Button illumination switchable to off
- CCT remembrance
- Copper free 5mm mirror
- 220-240V AC 50/60Hz
- IP44 rating
- RCM compliant
- Includes hanging kit and junction box

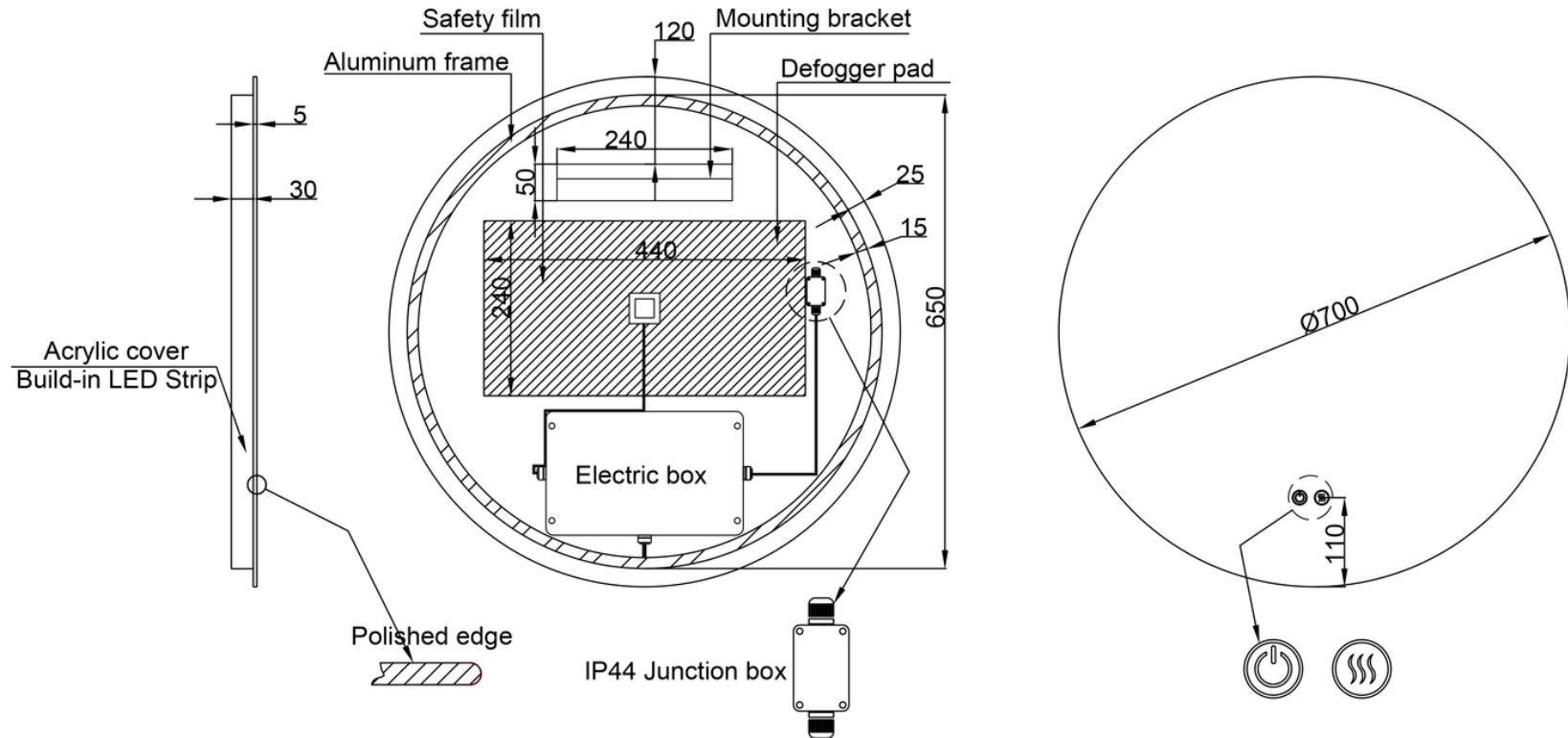

**NOTE: Must be installed by a licensed tradesman.**

www.lumixe.com.au | 1300 586 493

All measurements are in mm and are for reference only. We recommend using a physical product for final measurement and rough-in stages. While we aim to have all measurements perfect at the time of publication and production normal manufacturing tolerances are to be expected and technical drawings may differ from actual product. Lumixe reserves the right to make modifications with prior notice.

**Cleaning:** We recommend a 70% water and 30% methylated spirits mix with a microfiber cloth. If you have any questions please reach out to your sales consultant or contact Lumixe directly.

Updated 01/23

