

UNDER TILE HEATING

INSTALLATION MANUAL

Please read this instruction manual.

It includes important information that will assist you and save you time and money such as:

To calculate the wire spacing start with the M2 of the area to be heated.

Multiply this by 1000. Then divide this answer by the length of the element. The answer will be the spacing between the element runs.

**Please ensure you see page 5 for exact measurement details.*



Thank you.

Thanks for your purchase of Hotwire Heating.

We know that you will love it for years to come. We're so confident in our products that the heating element is backed with a lifetime warranty. *(conditions apply)*

This document is a step-by-step guide to ensure a perfect installation. Please take the time to read it and understand all the steps involved.

If you are unsure about any aspect, please contact our office. Our team is happy to assist you along the way.

We even have a nationwide network of installers who can complete the installation for you if you prefer.

So please contact us if you would like to engage one of our recommended installers.

Thanks again for choosing Hotwire.

Hotwire: Warm Your Soul

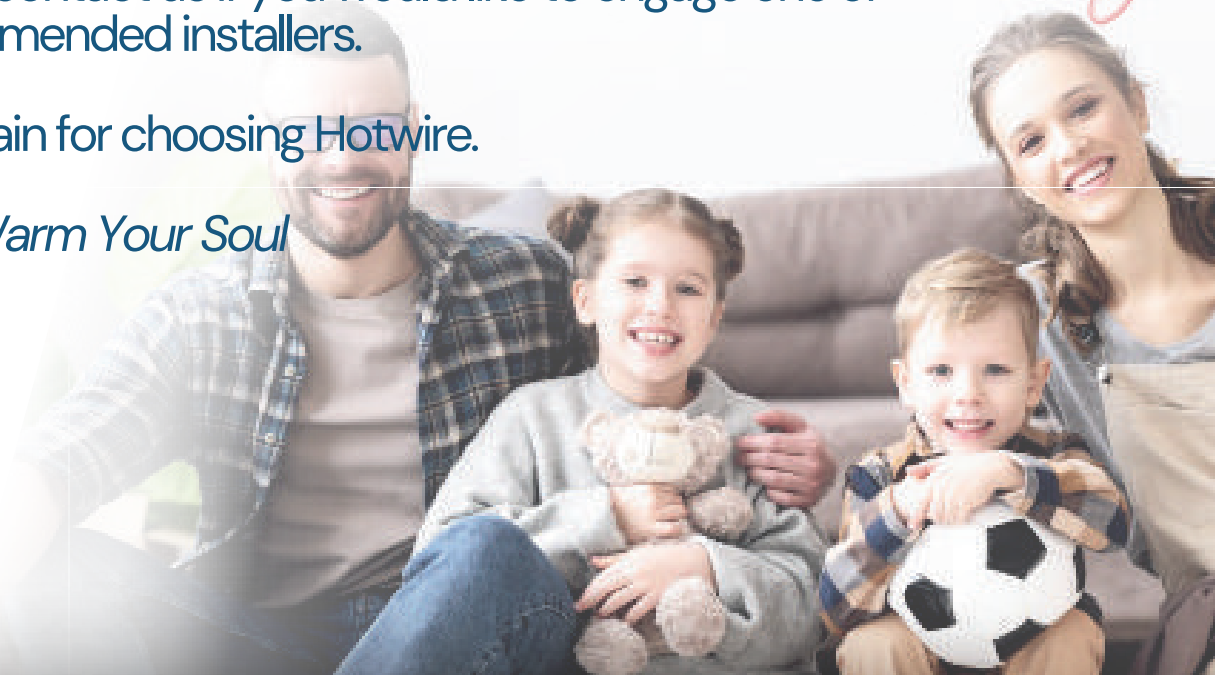

CONTENTS

Step 1 Read This Manual	Page 4
Step 2 Pre wire or “Rough In”.....	Page 4
Step 3 Cold Tail Channels.....	Page 5
Step 4 Floor Preparation.....	Page 5
Step 5 Primer.....	Page 5
Step 6 Cable Spacing.....	Page 6
Step 7 Plan the Installation	Page 7
Step 8 Check the Element	Page 7
Step 9 Tape	Page 8
Step 10 Roll out Element	Page 8
Step 11 Half Way	Page 8
Step 12 Nearly Finished Installing the Element	Page 9
Step 13 More Tape.....	Page 9
Step 14 Install the Floor Probe.....	Page 10
Step 15 Power Supply.....	Page 10
Step 16 Connect Continuity Alarm	Page 10
Step 17 Take a Picture.....	Page 11
Step 18 Protecting The Element	Page 11
Step 19 Notice to Tilers	Page 12
Step 20 Connect The Thermostat	Page 12
Connecting systems over 20m2	Page 13
Materials Check List	Page 15
Tilers Instructions	Page 15
Do’s and Don’ts	Page 16
Footnotes	Page 16
Appendix	Page 17
Customer Warranty	Page 18



STEP 1 READ THIS MANUAL

Please read this manual. It includes everything you need to know to successfully install Hotwire.

Incorrect installation of Hotwire may lead to any warranty claim being denied.

In some States and Territories of Australia the installation of Hotwire Under Tile Heating must be performed in its entirety by a licensed electrical contractor. Whilst in others a licensed electrical contractor is only required for the connections to the thermostat.

Please check with your local electrical authority or Electrical Contractor to verify the requirements applicable to your State or Territory.

The Hotwire element cannot be cut, shortened or lengthened in any way.

Hotwire kits are provided based on the M2 of the floor you are wanting to heat.
(See Pg 6 for more on kit sizing.)

This element must be installed immediately under the tile. If you are wanting to install under or in a sand and cement screed you have the wrong element. Please contact your place of purchase.

NOTE: WATER PROOFING

You can install Hotwire under or on top of the waterproofing.

However please note the following,

1. Most self levelling products cannot be installed on top of water proofing. If unsure please contact the manufacturer of the brand you are using.

2. Primer is not required over most waterproofing membranes. Please speak to your tiler or waterproofer about this. Hotwire accepts no responsibility for incorrect products used in this step.

STEP 2 PRE WIRE OR "ROUGH IN"

Three things are required before Hotwire can be installed. Please see the diagram.

1. Power supply. You will need power capable of running the Hotwire element you are installing. *Eg 800 watts*
2. Flush Box. A vertical flush box will need to be installed. This is a standard light switch / power point plate.
3. Draw Wire. You will need a draw wire through the wall cavity or chased into wall (if brick) and run through conduit.

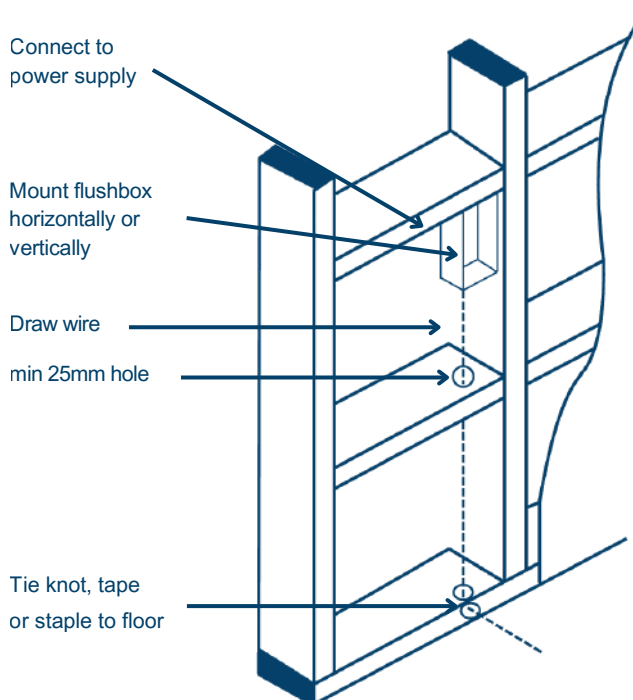

STEP 3 COLD TAIL CHANNELS

To start your installation process, you will need to dig out two channels, at a minimum of 10mm wide, 150mm long, and 5mm deep.

See picture below

The cold tails are conductive cables that are fitted to each end of the element. As the title says they are cold and it is this part of the cable that runs up the wall cavity. The join between the element and the cold tail is a bit thicker than the rest of the cable so you will need to dig a small channel.

Your Hammer drill or chisel should do the job, depending on the flooring. Each cold tail join must be completely fitted below the tile level. Failure to do so will void your warranty.



Note:

If when cutting the grooves in the floor you need to cut into the water proofing (*as in the picture*), the water proofing will need to be touched up again after your work.

Check with the water proofer before taking this step. They may be able to repair with a polyurethane sealant.

STEP 4 FLOOR PREPARATION

The floor needs to be completely clean. Sand, lumps of gyprock, glue, etc. will affect your Hotwire installation. Make sure you clean the floor well. Sweep up all the dust, a once over with the vacuum is also a good idea if you have one handy.

STEP 5 PRIMER

One option to protect the element is to install a 5mm thick self leveling screed over the element (more on that later).

Fibre Glass mesh can also be used. However in either case the floor will need to be primed to assist the tiler.



Now you have the preliminaries done you can get down to installing Hotwire.

STEP 6 CABLE SPACING

This is really important to an excellent Hotwire installation, so please read this carefully.

Calculate the EXACT m2 of the area to be heated. We don't heat under anything that is fixed. For example, vanites, toilet in bathrooms, kitchen cupboards, and permanent entertainment Units in living areas.

Take the m2 you are left with and multiply it by 1000 (this is to bring the measurement to square millimeters). Then divide that answer by the length of the element. This is printed on the side of the spool. The answer will be the cable spacing and should be between 50 and 75 mm. If your answer is outside this check your measurements again as you have made a mistake or have the wrong element. If this is the case **DO NOT** proceed with the installation.

$$\text{Cable Spacing} = \frac{\text{M2 of floor} \times 1000}{\text{Length of Cable}}$$

The above formula is the spacing C to C (centre to centre) of the cable runs. To ensure the exact measurement is correct take 4mm off your calculation to compensate for this.



"Cable Length, Wattage, and Ohms reading are printed on the side of the Element"

It is a good idea to cut a jig to the size you need rather than use a tape measure the whole time. An off-cut of wood is fine; we used an off-cut of Hot Glue stick.



Note for areas over 20 m2.

If your area is over 20 m2 you have been supplied with two elements. These must be run in parallel and not joined together. Basically you have to install one element on one half of the floor and the other on the other half. So do the above measurement with 50% of the m2.

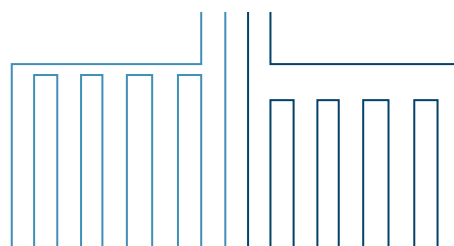

STEP 7 PLAN THE INSTALLATION

This is a step where you can come undone if you don't plan properly.

The Hotwire element must start and finish in the same place and CANNOT be cut or shortened in any way. So have a look at the room and work out what is the most logical and simple way to run the cable around that room.

You want to be doing as many long runs as possible.

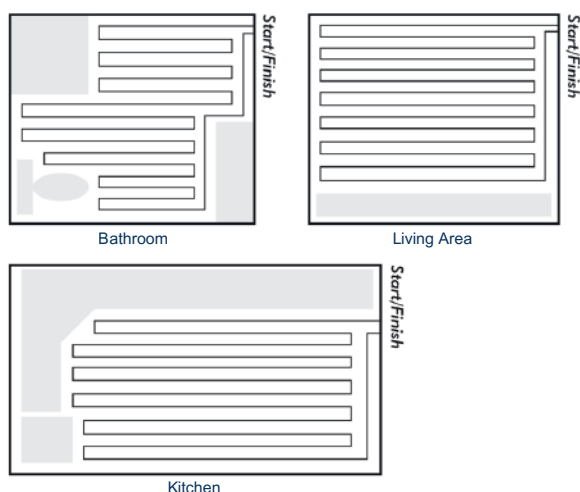

Try and leave the longest wall until last. That way if you have a little too much or too little cable left you can make an easy adjustment by coming a bit further away or going right up close to the wall. Neither option will affect the heating of the room in any way.

STEP 8 CHECK THE ELEMENT

Before installing the element, it is always a good idea to ensure it has not been damaged during transit.

We check every element before it leaves our warehouse but there is the possibility that it may get damaged by a courier.

If you have a multimeter then you can check the cable against the following table.

Watts*	m2 (min)	m2 (max)	Cable Length	Ohms	Amps
200	1.00	1.30	18	264.50	0.87
300	1.40	2.00	27	176.33	1.30
400	2.10	2.60	36	132.25	1.74
500	2.70	3.30	45	105.80	2.17
600	3.40	4.00	54	88.17	2.61
700	4.10	4.60	63	75.57	3.04
800	4.70	5.30	72	66.13	3.48
900	5.40	6.00	82	58.78	3.91
1000	6.10	7.10	90	52.90	4.35
1250	7.20	8.90	112	42.32	5.43
1500	9.00	10.70	136	35.27	6.52
1750	10.80	12.50	160	30.23	7.61
2000	12.60	14.20	180	26.45	8.70
2500	14.30	17.80	220	21.16	10.87
3000	17.90	21.40	272	17.63	13.04

If you don't have a multimeter don't panic we have you covered.

In the Hotwire box is a continuity alarm. It's in a white box in the larger Hotwire box your floor heating came in.

If the alarm does not beep, you are good to keep installing. There is also another use for the alarm, so keep it handy; more about that after the element is down.

See page 10 for connection instructions of the alarm.

STEP 9 TAPE

You will need lots of bits of the cloth tape that is included in the box.

STEP 10 ROLL OUT ELEMENT

You are now ready to start rolling out the element and sticking it down.

Stick one end in the cold tail groove you cut earlier. Do not put any part of the black cable join inside the wall cavity. All black and blue cable must be on the floor.



Then start spreading the element around the floor using the jig you cut earlier.

Make sure no black or blue cable is touching when install is finished.



STEP 11 HALF WAY

You will notice a half way marker. It is a little piece of tape around the element. When you see this stop and look at where you are up to. If you are not sure if you are half way through the floor check your measurements. Measure the remaining m² and use 50% of the cable length to check if you are on target.

If you are a little more or under half way you can spread the cable runs out or close them up a bit. However, only do this if the difference is a mm or 2. If it is greater than this you may need to roll the cable up and change the spacing.



STEP 12 NEARLY FINISHED INSTALLING THE ELEMENT

When you are nearly finished (only 4 or 5 metres of cable left), you will need to go in reverse. Roll off all the cable and stick the second cold tail down. Then make the remainder of the element fit in the remaining space.

You may find it necessary to make one run a little shorter or close the cables up a bit. This is okay as long as it is not a high traffic point. In the picture you will notice the last run is a little short. This is perfectly acceptable as long as it is not the cable run right in front of the vanity!

If you are really stuck you can eliminate an area such as behind a door or down the sides of a vanity unit. Just check with the homeowner to ensure they are aware so that you don't have any problems later.

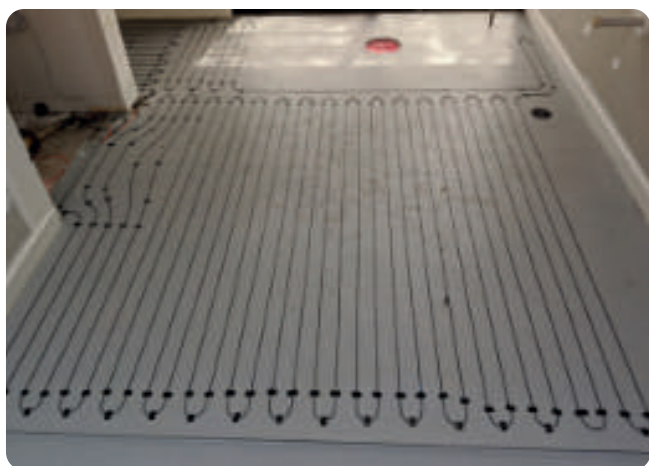

STEP 13 MORE TAPE

Stick any proud bits of element down. Some of the loops may have popped up a bit. You will also need to run a strip of tape right across the whole floor to ensure the cable does not get moved when installing the leveller. Its a good idea to run tape runs every metre.

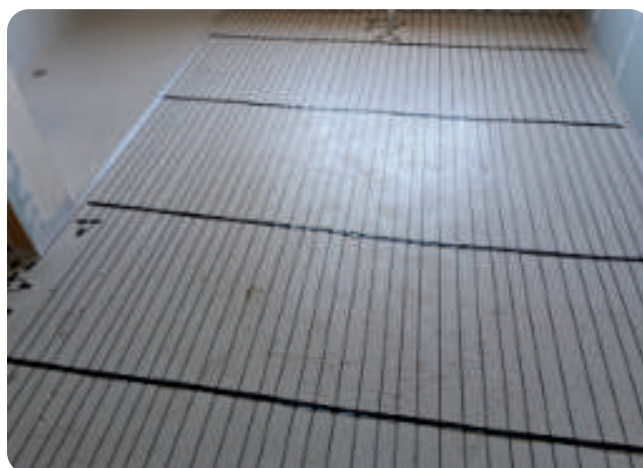

STEP 14 INSTALL THE FLOOR PROBE

You now need to install the floor probe. It should be in the box with the thermostat. Make sure you don't stick any tape over the end of the probe. It is also critical to ensure that the probe is exactly halfway between two cable runs. eg If your measurement was 60 mm. Ensure the end of the probe is 30 mm from one run of element and 30mm from another.

The Thermostat probe should be run in a conduit so it can be easily replaced if required. Warranty claims on probes will not be accepted if not laid in a conduit.



STEP 15 POWER SUPPLY

Tape the ends of all three cables (each cold tail and the floor probe) to the draw wire and gently pull the cable up the wall cavity or through the conduit to the position of the power supply. No part of the element can be run inside the wall. The entire cold tail join (black or blue cable) must be buried in the channel you dug at the start.

STEP 16 CONNECT CONTINUITY ALARM

Connect the continuity alarm again. This will ensure you have not damaged the cable during installation. It will also monitor the cable while you are laying the leveling compound and/or tiles.

1. Insert the green wire into "G"
2. Insert Blue wire to "L1"
3. Insert Brown wire to "L2"
4. Switch the tester on.
5. A Red Light then shows that the tester is on and working.
6. If you have a fault the tester will start "Beeping" If there is no "Beep" you can continue with the installation
7. If the beep sounds at any time, before or during installation STOP IMMEDIATELY as this means that damage has occurred to the element and you will need to repair it before continuing.
8. Keep the tester on until your tiling is complete.
9. If the tester light turns off you will need to replace the batteries.

It is a good idea to tape the alarm up with the tails so that it is not in your way while you finish the installation.



STEP 17 TAKE A PICTURE

Take a picture of the element layout. If there is ever a problem it will be handy to know how the element has been installed across the floor.

STEP 18 PROTECTING THE ELEMENT

There are two options for protecting the heating element.

1. The use of a Fibre Glass mesh
2. Covering the element with a self levelling compound.

FIBRE GLASS MESH

Fibre glass mesh is available from Hotwire. Please contact our office should you need supply of this product. The product is a self adhesive fibre glass mesh the dimensions of which are 1 m x 50m . It is simply spread out over the element and the self adhesive backing sticks to the floor and protects the element.

If using this product please ensure that you do not double one layer of mesh over another. This will stop the tile glue getting through to the floor and may cause issues with the tiles.

Please see the following picture of this method used in a living area and a bathroom.



SELF LEVELING COMPOUND

When using a self-leveling compound, we recommend you install it to a depth of 4mm so the element is just covered.

You should use the same brand of leveling and tile glue. Check with the manufacturer of your tile glue for the appropriate levelling product that is suitable for floor heating.

POUR THE LEVELLER

Pour in the furthest corner from the door and work your way out of the room.



Using a flat trowel spread the leveling. It should be very easy to push and will find its own level. To protect the cable ensure you only move the trowel along the cable and not across it. You can use the top of the cables as a guide for the depth. The outline of the cables will be visible in the finished product.



STEP 19 NOTICE TO TILERS

Inside this manual is a yellow flyer pointing out to tilers that Hotwire has been installed. Stick it to the wall in a prominent place. The flyer also has a place to write your name and number for them to call with any questions.

STEP 20 CONNECT THE THERMOSTAT

It is a good idea to leave the continuity alarm connected during the tiling. This will ensure that any damage is noticed immediately. It will involve either a second trip to connect the thermostat or leaving the connection to the second fix electrician.

CONNECTING SYSTEMS OVER 20 M2 OR 3KW

The Hotwire Thermostat has a 16 amp capacity. Simply follow the instructions in the box with the thermostat to connect the heating elements and the floor sensing probe.

If you have a system that is over 3kw you will need to install a contactor in the switch-board. If you are installing a 6kw system, you should also install a 32 mm conduit from the Thermostat to the floor.

We suggest installing a 25a, 32a or 40a contactor depending on the circuit size in the switch board.

Please consult your Electrician to ensure you have the right preliminary electrical work completed.

WIRING DIAGRAM FOR 6KW UNDER FLOOR HEATING SYSTEM.

Note:

All circuit and element cabling should be taken to the thermostat location for connection and serviceability.

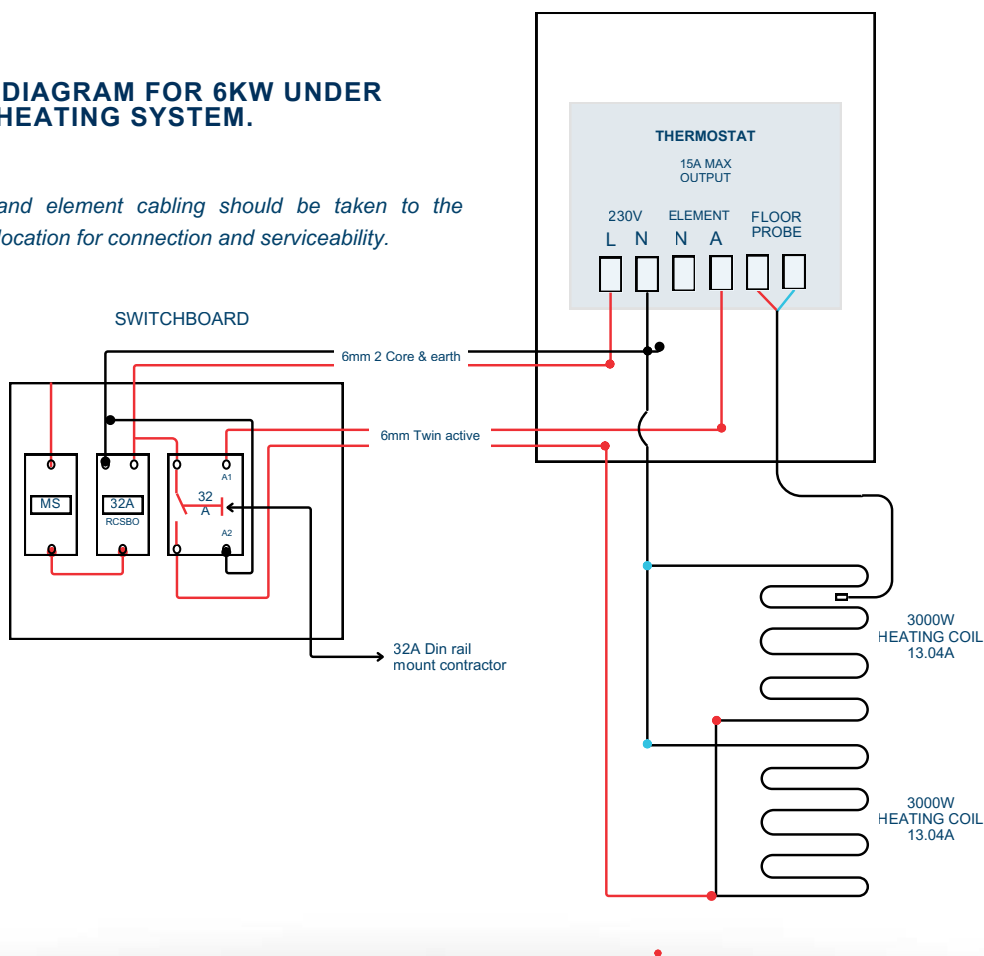

WIRING DIAGRAM FOR 1 X 32A CIRCUIT

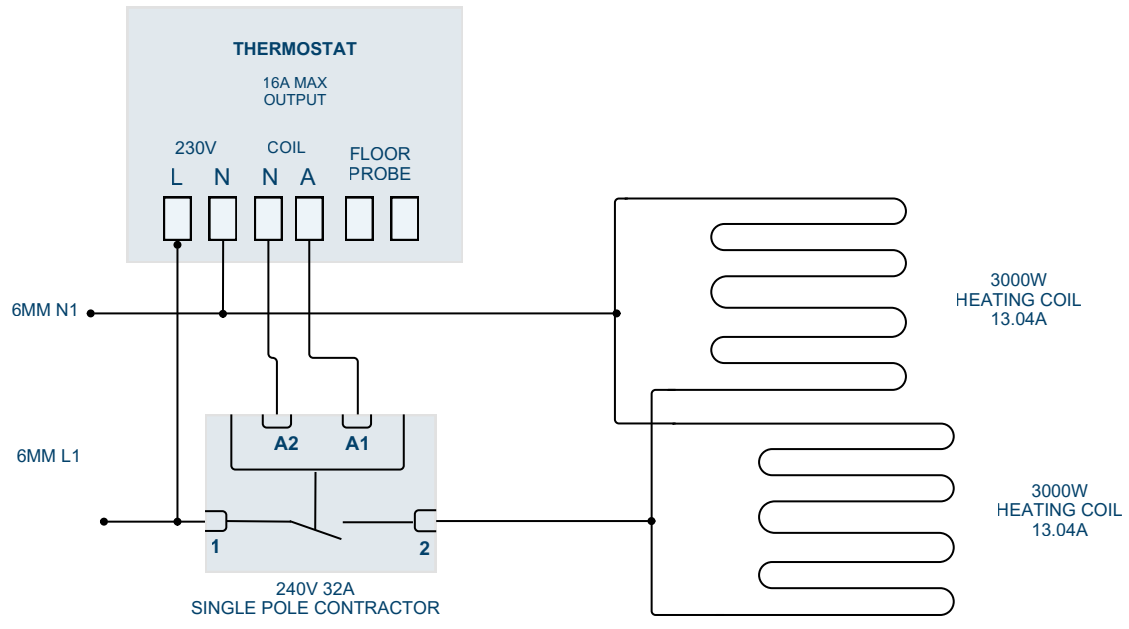

WIRING DIAGRAM FOR 2X16A CIRCUITS

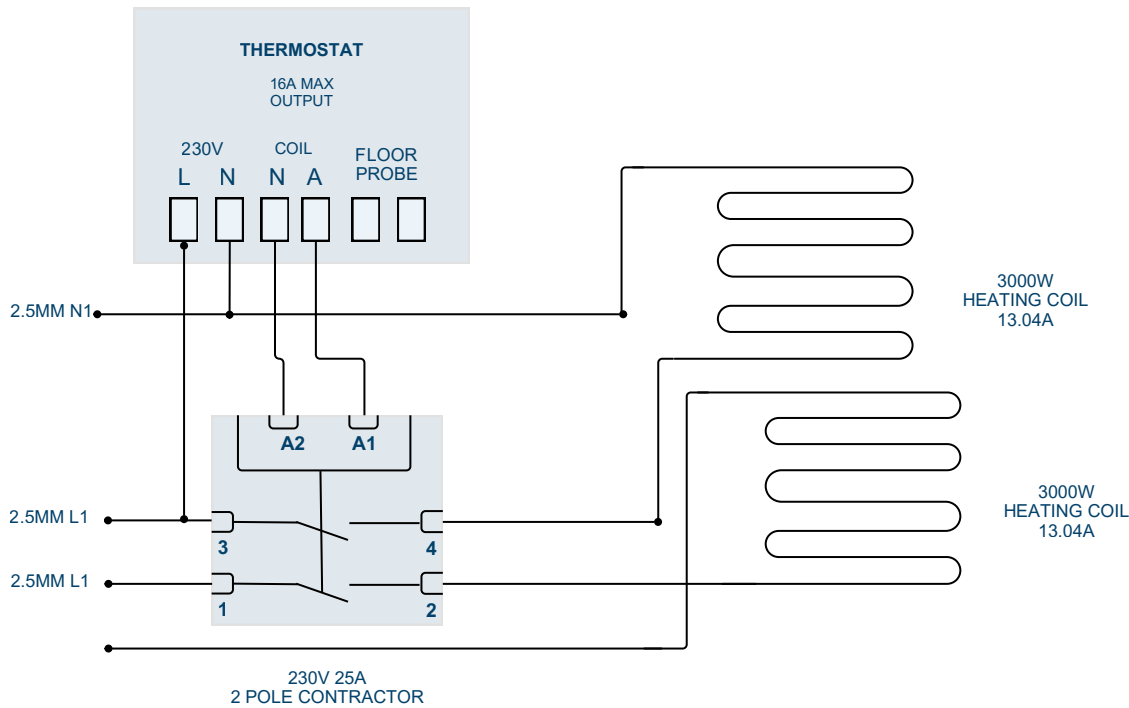

MATERIALS CHECK LIST

Provided from Hotwire:

- Hotwire Element:
- Thermostat: (including a floor sensing probe)
- Cloth Tape
- Continuity Alarm
- This Manual

You will also need:

- Broom
- Hammer Drill
- Bucket
- Mixer
- Flat trowel
- Tape Measure
- Leveller
- Primer

TILERS INSTRUCTIONS

It is the Tiler's responsibility to check the floor for suitability for tiling and to complete any floor preparation and waterproofing etc required before the heating element is installed.

The heating element incorporates double insulation with a multi stranded conductor and will withstand normal tiling practices. However we do ask you to note and take care of the following.

Wear soft soled shoes while tiling. Ensure that enough adhesive is used to eliminate hollows or voids under the tiles.

Do not carry out other work on top of the elements such as tile cutting.

Do not place ladders on the elements.

Close off the area to other trades before the tiling has taken place.

We recommend a 10mm plastic notched trowel be used to spread adhesive and that trowelling is done in the direction of the element wire. (If steel trowel is used check for any sharp edges which should be filed and removed).

Do not position tiles or other machinery on the heated floor area, and care must be taken, not to drop anything.

ELECTRICAL CONNECTION OF THE THERMOSTAT

All circuit wiring supply and thermostat connection must be undertaken in accordance with the current electrical standards and regulations. The heating units must be separated from other heating sources. Electrical supply circuits must be RCD (Residual Current Device) protected with a rated residual operation current not exceeding 30 mA.

OPERATION

Wait 7 days for the tile adhesive to dry before you turn your heating on. Once the heating is commissioned, the initial heat-up time will vary depending on the subfloor type (concrete or timber), insulation, thermal characteristics, and ambient temperature. Performance will improve with use.



DO'S & DON'TS

DO's

- Carefully read the installation instructions prior to commencing your installation.
- Check the element is working before you start.
- Ensure the surface is clean and clear of obstructions.
- Pre-plan your element layout and stay within the recommended element spacing.
- Maintain even element spacing.
- Protect the heating element from damage at all times.
- Plan required pre-work and drilling before you lay the element.
- Take care when tiling to make sure that you do not damage the element.
- Ensure that enough tile adhesive is used so as not to leave gaps or voids under the tiles.

DON'Ts

- Don't cut or shorten the heating element.
- Don't commence installation on concrete floors that are not fully cured.
- Don't allow the heating elements to cross or touch.
- Don't allow traffic over the heating element until the flooring has been laid.
- Don't remove the heating element off the spool except during installation.
- Don't store tiles sharp or heavy objects on the elements while tiling.
- Don't switch on the heating until the tile adhesive has fully cured.
- Don't install the element over uneven floor surfaces.

FOOTNOTES

The lowest ambient temperature that the heating element can be installed equals -80C.

The minimum radius for bending the heating element equals 20 mm.

The thickness of covering materials should be at least 5mm.

Contact the manufacturer for advice if materials other than those recommended are used.

The appliance is not intended for use by young children, or infirm persons, without supervision.

Young children should be supervised to ensure they do not play with the appliance. Laws in different states and territories of Australia differ. Please check with your local electrical authority if someone other than a licensed Electrician is able to lay the cable in your state or territory. In all states and territories all electrical connections including the thermostat must be carried out by a registered electrician.

All circuit wiring supply and thermostat connection must be undertaken in accordance with the current electrical standards and national wiring regulations.

The heating units must be separated from other heat sources.



APPENDIX

Floor Probe Readings

temp(°C)	resistance (KΩ)			resistance accuracy (%)		Temperature accuracy (°C)	
	Min value	Central value	Max value	ΔR	-ΔR	ΔT	-ΔT
0	31.426	32.116	32.817	2.185	-2.148	0.428	-0.421
1	30.051	30.697	31.354	2.139	-2.104	0.42	-0.414
2	28.626	29.227	29.838	2.089	-2.056	0.413	-0.406
3	27.274	27.833	28.401	2.039	-2.008	0.405	-0.399
4	25.991	26.51	27.038	1.989	-1.96	0.398	-0.392
5	24.772	25.255	25.745	1.94	-1.912	0.39	-0.385
6	23.615	24.064	24.519	1.89	-1.865	0.383	-0.377
7	22.517	22.934	23.357	1.841	-1.818	0.375	-0.37
8	21.474	21.861	22.253	1.793	-1.771	0.367	-0.363
9	20.483	20.843	21.206	1.744	-1.724	0.359	-0.355
10	19.452	19.783	20.117	1.691	-1.673	0.353	-0.349
11	18.648	18.957	19.27	1.648	-1.631	0.343	-0.34
12	17.799	18.085	18.375	1.6	-1.584	0.335	-0.332
13	16.991	17.257	17.525	1.552	-1.538	0.327	-0.324
14	16.224	16.47	16.718	1.505	-1.492	0.319	-0.316
15	15.495	15.722	15.951	1.458	-1.446	0.311	-0.309
16	14.801	15.012	15.223	1.411	-1.401	0.303	-0.301
17	14.142	14.336	14.532	1.364	-1.356	0.294	-0.293
18	13.515	13.694	13.875	1.318	-1.31	0.286	-0.284
19	12.918	13.084	13.25	1.271	-1.265	0.278	-0.276
20	12.351	12.504	12.657	1.225	-1.22	0.269	-0.268
21	11.811	11.952	12.093	1.18	-1.176	0.261	-0.26
22	11.297	11.427	11.556	1.134	-1.131	0.252	-0.251
23	10.808	10.927	11.046	1.089	-1.087	0.244	-0.243
24	10.343	10.452	10.561	1.044	-1.043	0.235	-0.235
25	9.9	10	10.1	1	-1	0.226	-0.226
26	9.469	9.569	9.669	1.044	-1.043	0.238	-0.237
27	9.059	9.159	9.259	1.088	-1.086	0.249	-0.249
28	8.669	8.768	8.868	1.132	-1.129	0.261	-0.26
29	8.298	8.397	8.495	1.176	-1.172	0.273	-0.272
30	7.945	8.042	8.141	1.22	-1.215	0.284	-0.283
31	7.608	7.705	7.802	1.263	-1.257	0.296	-0.295
32	7.287	7.383	7.48	1.306	-1.299	0.308	-0.307
33	6.982	7.077	7.172	1.349	-1.341	0.32	-0.318
34	6.69	6.784	6.879	1.392	-1.383	0.332	-0.33
35	6.413	6.506	6.599	1.435	-1.424	0.345	-0.342
36	6.148	6.24	6.332	1.477	-1.465	0.357	-0.354
37	5.896	5.986	6.077	1.519	-1.506	0.369	-0.366
38	5.655	5.744	5.834	1.561	-1.547	0.382	-0.378
39	5.425	5.513	5.601	1.603	-1.587	0.394	-0.39
40	5.206	5.292	5.38	1.644	-1.627	0.407	-0.403



CUSTOMER WARRANTY AGAINST DEFECTS FOR HOTWIRE UNDER FLOOR HEATING PRODUCTS

Turnkey International Pty Ltd (ABN 36 086 830 766) trading as Hotwire Heating.

ABOUT OUR PRODUCTS

Hotwire Heating elements are made of high-quality heating cable with FEP (teflon) insulated conductor, braided screen, and a black or blue PVC outer sheath providing an invisible, comfortable, fast, dust-free, quiet, and energy-saving floor heating solution.

All Hotwire Floor Heating systems include:

- Heating Element
- Fully programmable thermostat touch screen
- Alarm
- Tape
- Installation Manual
- Floor Probe

Wi-Fi and Dual Thermostats are available as an upgrade.

Hotwire Heating warrants that all of our under-the-floor heating cables are free from defects in material and workmanship in their manufacture.

Our under-the-floor heating cables are carefully tested, including resistance measurement and 1500V insulation test (high voltage test) before their shipment, and are well packed to avoid damage during transit.

AVAILABILITY OF INSTALLATION & SERVICING

Hotwire Heating products are provided based on the measurement of the floor you are wanting to cover. If you need an installer, we can help there too. Hotwire has the largest network of qualified floor heating installers in Australia. Simply look up the closest installer to you on our “Installations” page on our website.

AUSTRALIAN CONSUMER LAW WARRANTIES

Hotwire Heating’s Goods come with guarantees that cannot be excluded under the Australian Consumer Law (ACL).

Under ACL, Consumers who have been supplied our Goods by a builder, a third party, or who have purchased a home in which our Goods are installed are entitled to access to repair/replacement parts, a guarantee that the Goods are of acceptable quality and the express warranties below. These Consumers are not entitled to the same rights as a Consumer who has purchased Goods directly from Hotwire Heating.

EXPRESS WARRANTIES

Hotwire Heating provides support to Consumers (regardless of whether they purchased Goods directly from Hotwire Heating or not), in respect of Goods supplied by Hotwire Heating. This may involve Hotwire Heating attending your property to assess the issues with the Goods and if the issue is a major defect of Goods or a manufacturing fault (subject to Hotwire Heating’s Terms and Conditions and the provisions of this Consumer Warranty), then Hotwire Heating will



attend to rectification of the issue, at the cost of Hotwire Heating. If the issue is not a major defect of Goods or a manufacturing defect with the Goods, then Hotwire Heating may be able to assist You in resolving the issue, and will discuss with You what can be done and the costs associated.

Often, issues arise from the Goods having not been installed by a licensed electrician, or having been installed incorrectly. Hotwire Heating supplies an Installation Manual to all purchasers at the time of sale of the Goods and advises purchasers that the Goods must be installed by a licensed electrician in accordance with the Installation Manual. If the Goods are not installed by a licensed electrician in accordance with the Installation Manual, this will void any warranty applicable to the Goods. In these circumstances, Hotwire Heating may be able to assist the Consumer in any issues with the Goods (at the cost of the Consumer), however, Hotwire Heating is not liable for issues arising from installation of the Goods either:

- By a person who is not a licensed electrician; or
- Resulting from failure to install the Goods in accordance with the Installation Manual.

EXTENDED WARRANTY [LIFETIME]

Hotwire Heating undertakes to repair or, at its sole discretion, to replace any part of the Goods supplied by Hotwire Heating which are found to have a manufacturing defect for the lifetime of the Goods from the date of purchase, subject to the following conditions.

- (i) the original flooring material, being that flooring installed with the initial purchase of the floor heating system, remains in situ; and
- (ii) the product has been duly registered on the Hotwire website [within 60 days of installation], accompanied by the submission of both the proof of purchase and a completed Hotwire Element Testing record.

Any warranty in relation to the thermostat is limited to 2 years.

YOUR OBLIGATIONS

In order to make a claim on the Goods and Services of Hotwire Heating, either under the ACL or the Extended Warranty provided herein, the Consumer must cease using the Goods immediately, contact Hotwire Heating from the outset of the issue, prior to engaging any tradespersons or attempting to repair the Goods, and must follow any reasonable instructions or provide any reasonable information requested by Hotwire Heating.

Any repairs or replacement of the Goods must be performed by Hotwire Heating (or its authorised contractors). Hotwire Heating shall not be responsible for any repairs performed to the Goods without the knowledge or authority of the Hotwire Heating.

EXCLUSIONS

Hotwire Heating does not provide Statutory Warranties or Extended Warranties in any of the following circumstances:

1. The Purchaser/Consumer fails to comply with Hotwire Heating's Installation Manual in relation to the fitting, installation and use of the Goods;
2. The Goods installed by non-Hotwire Installer or a person who was not a licensed electrician;
3. Unauthorised repairs or alterations made to the Goods;
4. Goods being subjected to improper voltage or power surges, misused, damaged by accident, force of nature or any other acts beyond Hotwire Heating's reasonable control;
5. The Goods being improperly installed or installed other than strictly in accordance with the Installation Manual (other than where such improper or other installation is carried out by an Authorised Installer);

6. The Consumer failing to provide the required document called “Hotwire Element Testing” upon request;
7. The Consumer failing to provide Proof of purchase (clearly stating the date of purchase);
8. Where there is a failure to complete the “Hotwire Element Testing Record”, as set out in the Hotwire Heating Element Booklet; or
9. Calls to replace batteries, programme or re-program thermostats and/or controllers, replace fuses or reset residual current devices or circuit breakers.

The total maximum liability of Hotwire Heating in all cases (save for those under ACL) is limited to replacing the Goods, repairing the Goods or repayment of the purchase price of the Goods, whichever is the lesser.

Hotwire Heating will not be liable for any incidental expenses (including costs of inspection, testing, removal, reinstallation, storage or transportation), any other charges, costs or expenses of the Consumer or any third party, personal injury, incidental damages, consequential losses, loss of profit, costs of business interruption, loss of opportunities or any like claims whatsoever arising from any use of, or incidental to, the Goods or their failure to operate.

If any component or part of the Goods is manufactured by a third party or supplied to Hotwire Heating by a third party, any warranty offered by Hotwire Heating in relation to the Goods or a component part of the Goods will be limited to Hotwire Heating’s right of redress (if any) against the manufacturer or supplier of the component part of the Goods.

HOW TO CLAIM UNDER WARRANTY

Claims under warranty must be made by contacting Hotwire Heating on the telephone number, email or postal address below:

Hotwire Heating

Factory 1 / 7-9 Newcastle Rd,
Bayswater Vic 3153

Telephone: 1300 797 060

Email: info@hotwireheating.com.au



NOTES

Copyright 2023 Hotwire IP Pty Ltd. All rights reserved. This article may not be reproduced, distributed, or transmitted in any form or by any means, including photocopying, recording, or other electronic or mechanical methods, without the prior written permission of the copyright holder.



1300 468 947
HOTWIREHEATING.COM.AU

Copyright 2023 Hotwire IP Pty Ltd. All rights reserved. This article may not be reproduced, distributed, or transmitted in any form or by any means, including photocopying, recording, or other electronic or mechanical methods, without the prior written permission of the copyright holder.

