

Installation manual and care guide

MB09

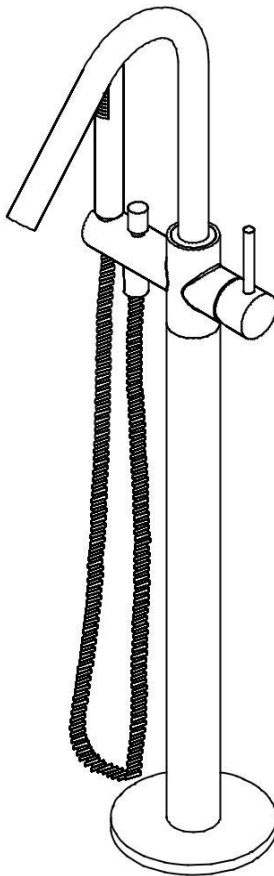

Care and Cleaning Instructions

Do not apply physical items (such as tools) directly to the product as this may cause irreparable scratches.

Never use detergents, harsh cleaning products, citrus based cleaners, acidic chemicals, or abrasive cleaners.

When your tapware remains dry in use, a soft cloth can be used to remove surface dust or wipe over with warm soapy water using only soft or microfiber fabric.

Use of wax based furniture cream should be avoided as these can result in a build-up of deposits, which could detract from the appearance.

Do not use undue pressure and try to wipe in one direction only.

Installation and testing

Do not install tapware using any form of acetone silicones.

Cartridges and diverters are tested and assembled prior to dispatch; no self-assembly and disassembly is required.

All underground components should undergo a 30-minute water test under 0.8pa before sealing. The water test should be conducted with close attention and with no signs of water leak. The installer is deemed responsible for any concealed leaks that are identified after installation.

Underground pipes should be installed strictly as per the installation manual; exchanging any parts supplied with the product is strictly prohibited and will void the warranty.

MAXIMUM: Temperature 75 degrees & Pressure – 1,000kPa.

MINIMUM: Temperature –3 degree & Pressure – 150kPa.

Note: AS/NSZ 3500.1-2003 (Clause 3.3.4) specifies 500kPa maximum water supply pressure at any outlet within a building for new installations.

Water pipes must be cleaned and flushed before installation. Impurities could destroy the cartridge, diverter, and aerator.

Gloves should be used and tools should not contact the product during or after installation as this may damage the shape or finish.

Problems and Solutions

If the water is not flowing as intended, please ensure the angle valve is opened fully.

If the water flow is coming out in an irregular stream, carefully remove and clean the aerator.

If the water temperature is not adjustable (changing from hot to cold or cold to hot), please ensure the angle valve and connection pipe is correctly installed.

Checking List

	Name	QTY.
1	spout	1
2	hand shower	1
3	hose	1
4	S2.5mm hex wrench	1
5	S4mm hex wrench	1
6	connecting pipe	1
7	water inlet pipe	2
8	M5x15 hex. bolt	8
9	M5 washer	8
10	water test base	1
11	rubber ring	1
12	rubber water stop	2
13	dustproof cover	1
14	fixing nut	1
15	rosette	1
16	expansion anchor bolts	4
17	plastic box	1
18	manual	1
19	water pipe	1

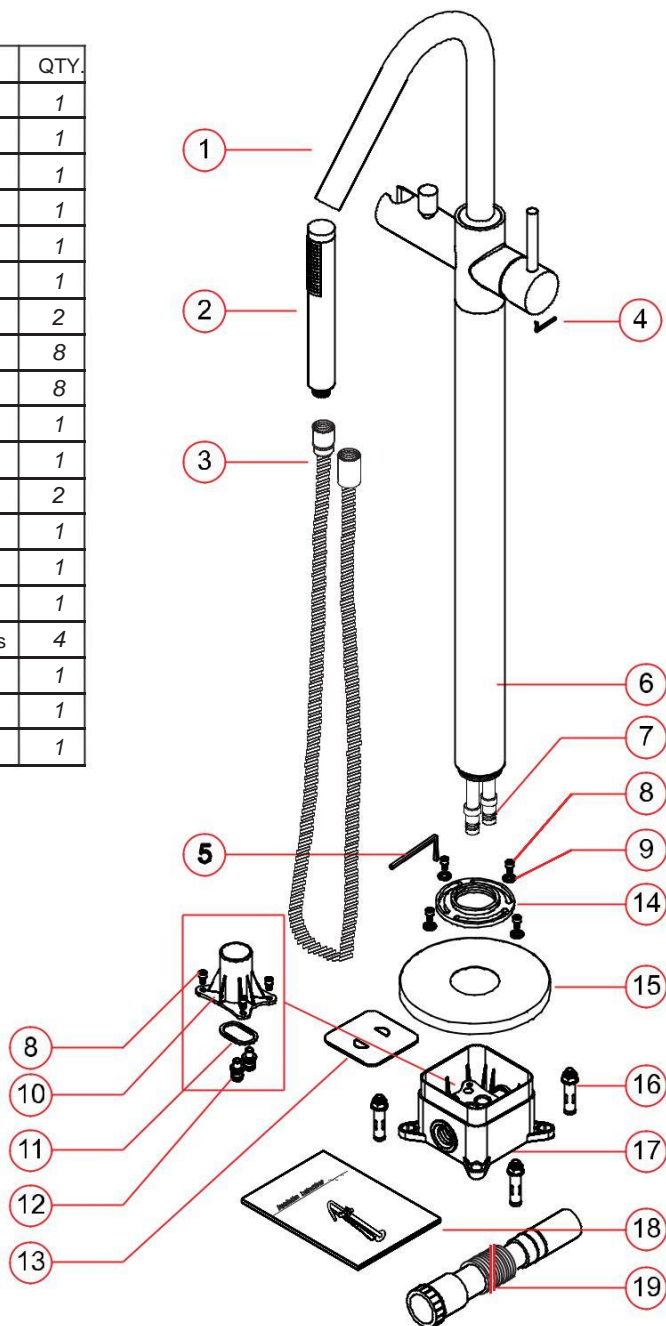

Disassemble and remove

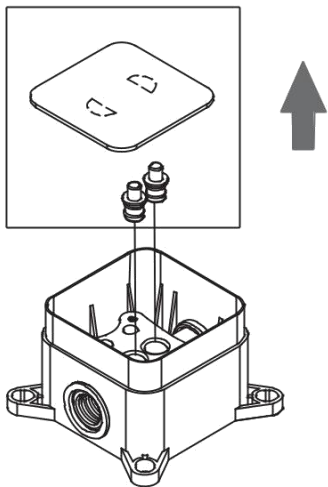

Insert the dustproof cover

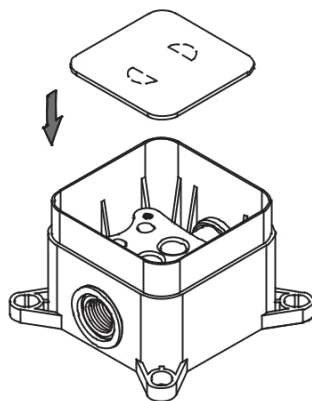

Align and position the tap

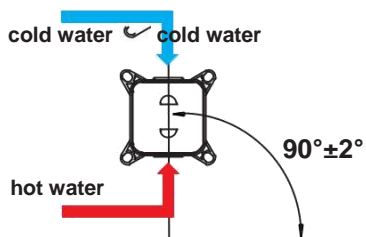

Note:

Please connect the hot and cold water pipe for this box correctly according to the instructions.

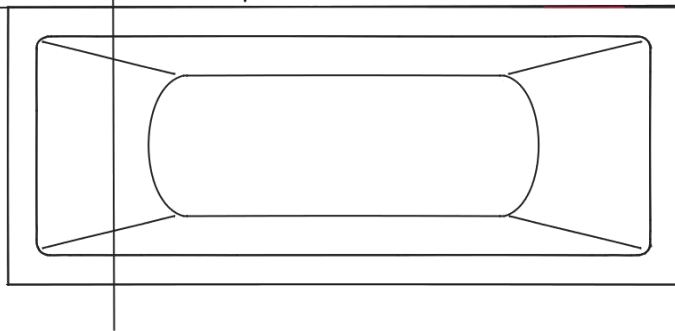

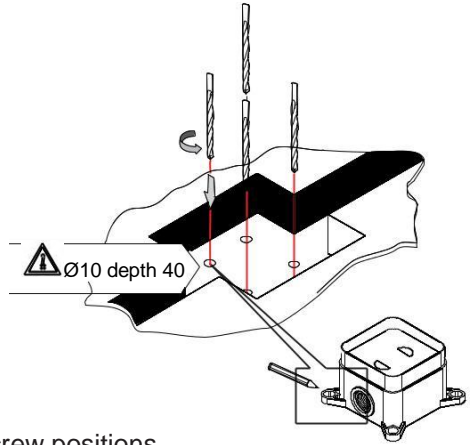
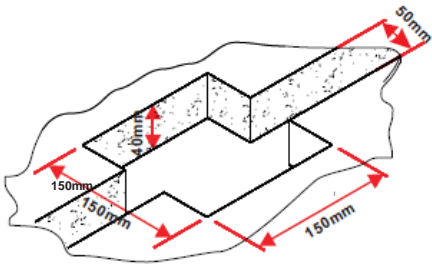

Align and affix the screw positions

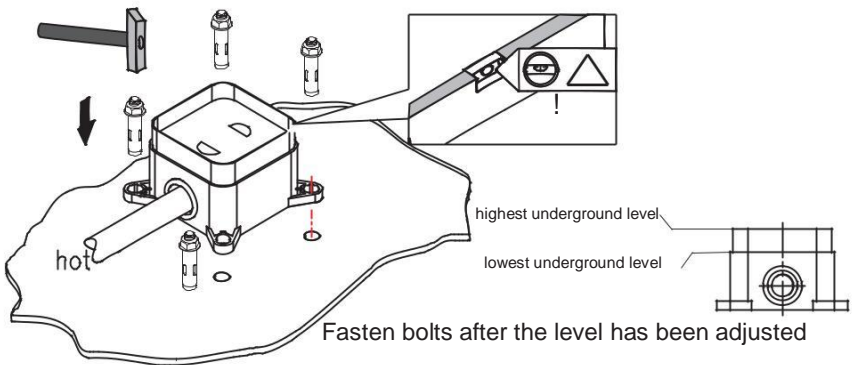
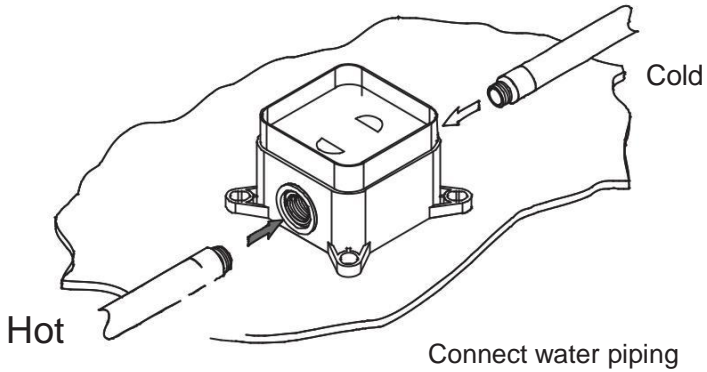

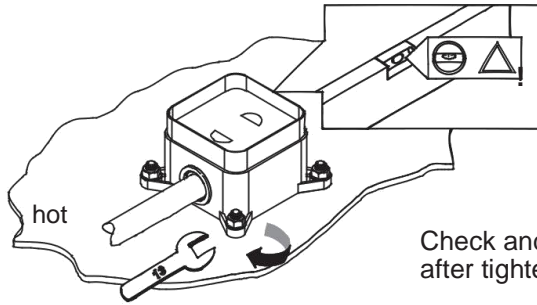

Check and adjust the level after tightening bolts.

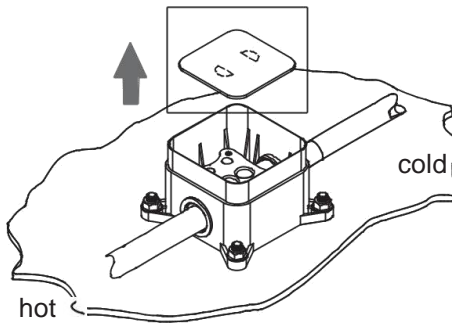

Remove the cover plate

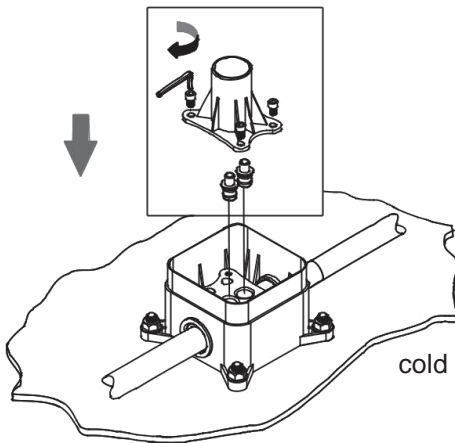

hot

Install the water test parts

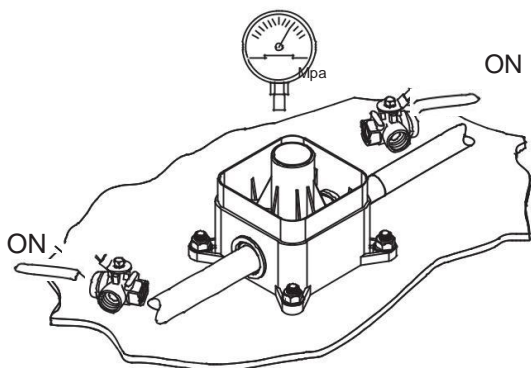

Turn the water on below 0.8Mpa of pressure. Maintain for 30 minutes and check for water leaks.

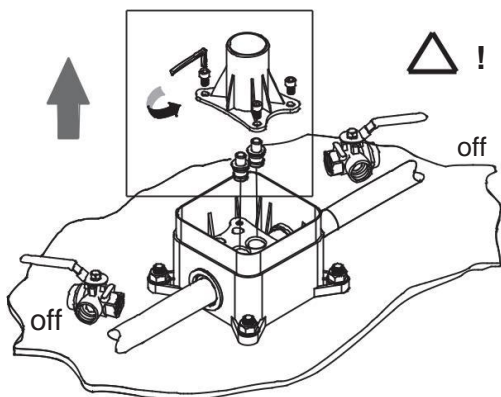

Caution:
Decompress the water before unfastening screws

Turn off the water and remove the testing parts.

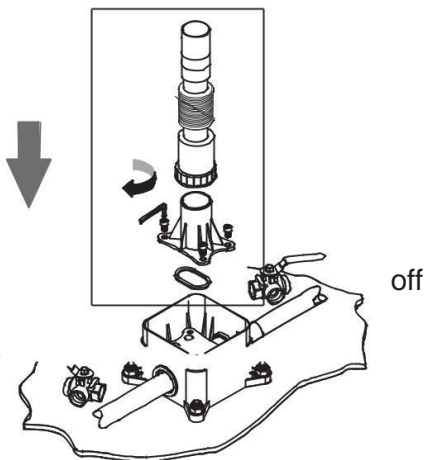

Install the pipe cleaning parts.

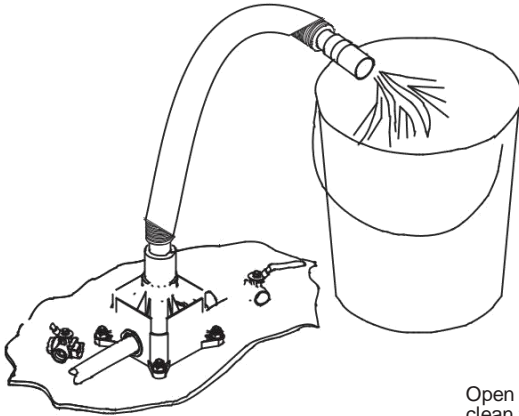

Open the valve to flush the water and clean the pipes.

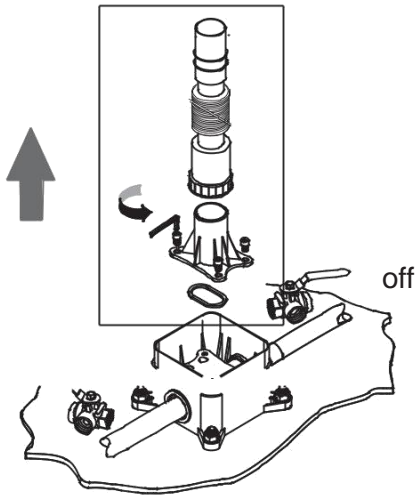

Turn off the valve and remove the pipe cleaning parts.

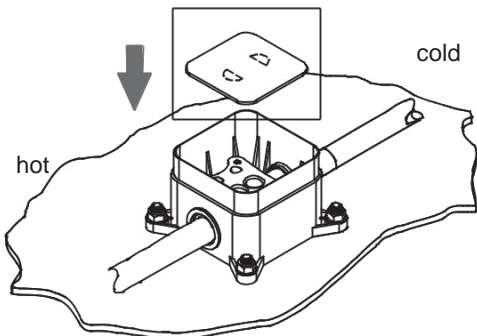

Replace the cover

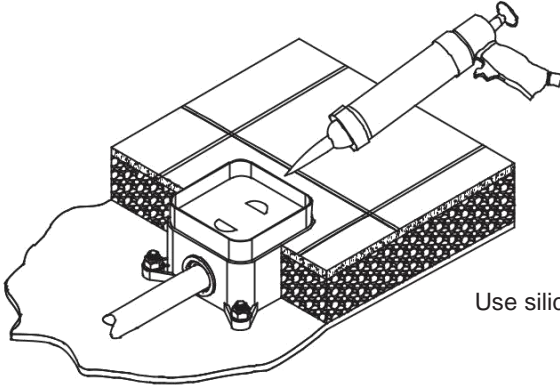

Use silicon to close tile gaps.

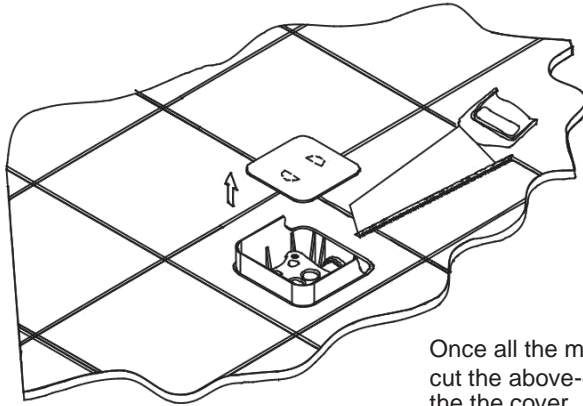

Once all the materials have dried,
cut the above-ground parts and remove
the the cover.

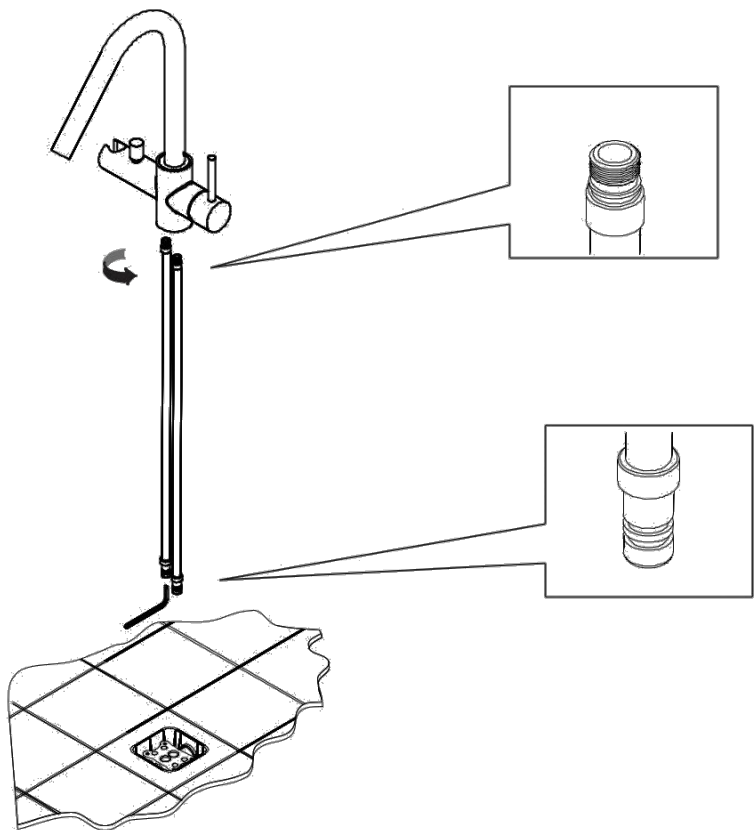

take out the 2 water inlet pipes from the packing box, fasten them onto the spout,

CAUTION: One end with thread should be upward, another end with 2 rubber rings is downward.

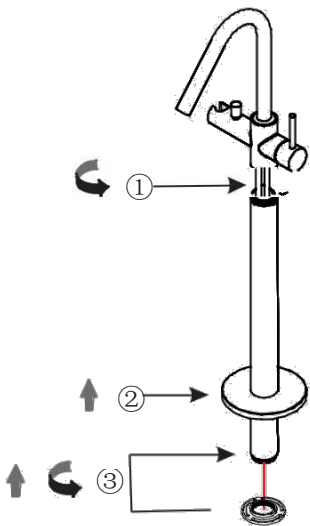

① Fasten the spout to the connection pipe.

② Install the rosette and be careful to avoid scratching.

③ Fasten the brass nut to the Body. Use thread glue if required.

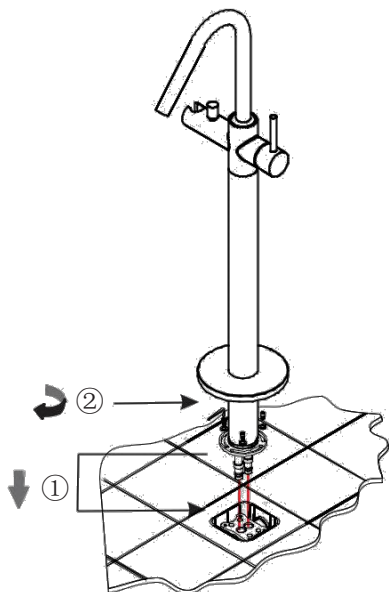

① Insert the 2 water pipes in the tap holes in the plastic box underground.

② Fasten the brass nut with 4 screws.

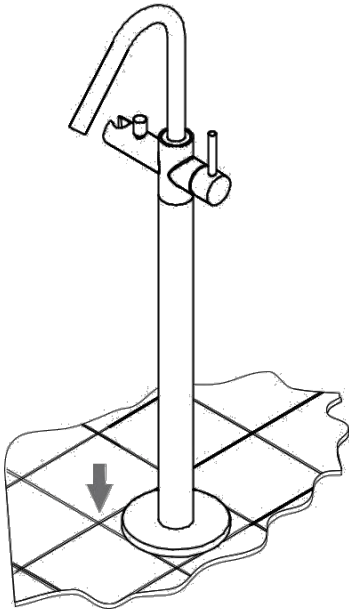

Push the rosette smoothly and firmly down.

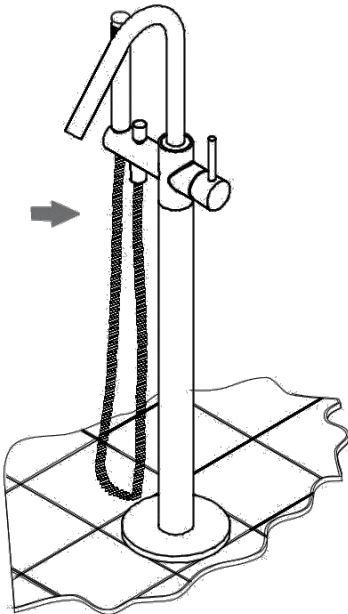

Install the hand shower and hose.

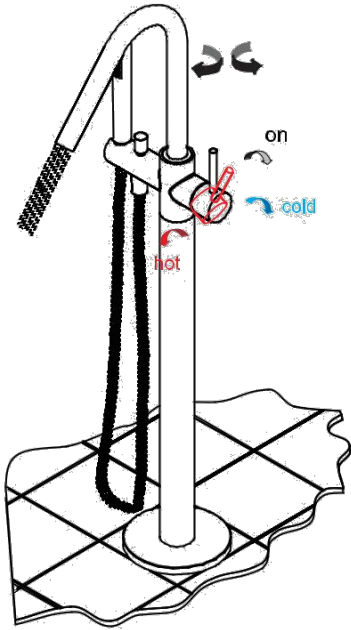

The unit can be rotated 360°

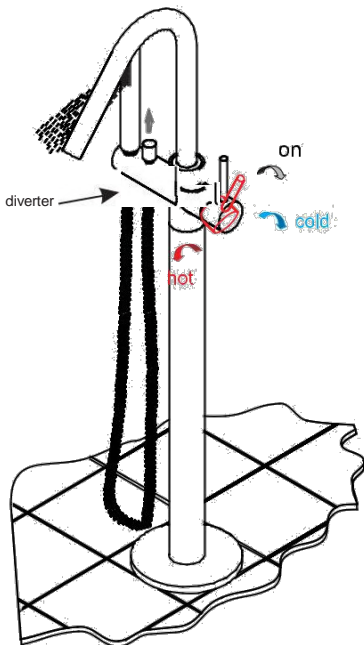

Switch between the spout and hand shower by using diverter.